



## CE-CC991IR

Vandal/Weather Resistant Day/Night Dome Camera

- SONY 1/3" CCD (Ex-View HAD)
- 480 TVL Resolution
- 18 IR LEDs
- 3.8 ~ 9.5mm Lens
- 3-Axis Adjustment
- DC12V / AC24V

### Dimensions

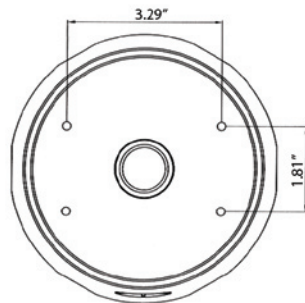
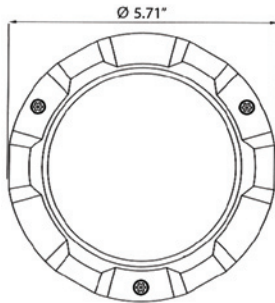
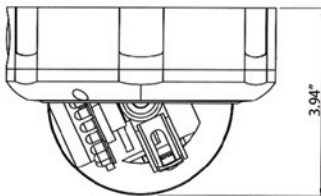

### Specifications

Camera	CE-CC991IR
<b>Image Sensor</b>	1/3 Inch SONY CCD
<b>Resolution</b>	480 TV Lines Color, 510 TV Lines B&W
<b>IR LEDs</b>	18 pcs
<b>Effective Pixels</b>	768 (H) x 494 (V)
<b>Scanning System</b>	2:1 Interlace
<b>S/N Ratio</b>	More than 48dB (AGC Off)
<b>Sync System</b>	Internal
<b>Scanning Frequency</b>	15.734 KHz (H), 59.94 Hz (V)
<b>Minimum Illumination</b>	0.5 Lux, 0 Lux with IRs
<b>Shutter Speed</b>	1/60 ~ 1/100,000 sec.
<b>Lens</b>	3.8 ~ 9.5mm Lens
<b>Video Output</b>	1.0 Vp-p, 75Ω
<b>Power Consumption</b>	Max. 160mA; Max. 320mA with IR LEDs
<b>Power Requirement</b>	DC12V / AC24V
<b>Operating Temperature</b>	-20°F ~ 122°F
<b>Operating Humidity</b>	90% RH Max.
<b>Dimensions</b>	5.71" (D) x 3.94" (H)
<b>Weight</b>	2.20 lbs.

Information in this document is subject to change

#### Recommended Power Supply

All Clinton Electronics Power Supplies