



CE-VPCD986-3X

Vandal/Weather Resistant Day/Night Dome Camera

- SONY 1/3" CCD (Super HAD)
- 480 TVL Resolution
- 2.9 ~ 10mm Lens
- 3-Axis Adjustment
- True Day / Night: Filter Switchable
- DC12V / AC24V

Dimensions

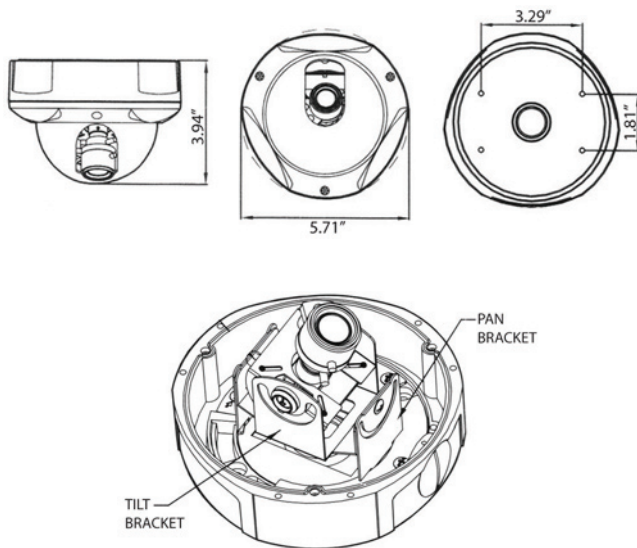

Specifications

Camera	CE-VPCD986-3X
Image Sensor	1/3 Inch SONY Super HAD
Resolution	480 TV Lines
Effective Pixels	768 (H) x 494 (V)
Scanning System	525 Lines, 2:1 Interlace
S/N Ratio	More than 50dB (AGC Off)
Sync System	Internal
Scanning Frequency	15.734 KHz (H), 59.94 Hz (V)
Minimum Illumination	0.5 Lux / F1.2, 0.03 Lux D/N
Shutter Speed	1/60 ~ 1/100,000 sec.
Lens	2.9 ~ 10mm Vari-Focal F1.2
Video Output	1.0 Vp-p, 75Ω
Power Consumption	Max. 184mA (AC24V), Max. 248mA (DC12V)
Power Requirement	DC12V / AC24V
Operating Temperature	-20°F ~ 122°F
Operating Humidity	Within 90% RH
Dimensions	5.71" (D) x 3.94" (H)
Weight	2.18 lbs.

Information in this document is subject to change

Recommended Power Supply

All Clinton Electronics Power Supplies

Optional Accessories

CE-VPWB

Wall Mount Bracket