

CE-S320-B

INSTALLATION GUIDE

Included Items:

- Power Supply Unit
- Instructions

Required Items:

- Phillips Head Screwdriver
- Wire Crimpers

Optional Items:

- 1/2" x4" Bolts, Washers, and Lock Nuts or similar (for Truss Mounting)
- 1/4" Bolts or Screws (for Wall Mounting)
- Rack Mount Screws x 4 (for Rack Mounting)
- Wrenches or Sockets for bolt tightening

This device complies with part 15 of the FCC Rules. Operation is subject to the following two conditions: (1) This device may not cause harmful interference, and (2) this device must accept any interference received, including interference that may cause undesired operation.

NOTE: This equipment has been tested and found to comply with the limits for a Class A digital device, pursuant to part 15 of the FCC Rules.



TO REDUCE THE RISK OF ELECTRIC SHOCK,
DO NOT DISASSEMBLE
NO USER SERVICEABLE PARTS INSIDE.
REFER SERVICING TO QUALIFIED SERVICE PERSONNEL.

1. Before any installation or maintenance work, please disconnect your system from the utility. Ensure that it can't be reconnected inadvertently!
2. Installation and service should be done by qualified personnel only. All work should conform to local codes.
3. Using replacement parts and/or accessories not approved of by Clinton Electronics may void warranty.
4. Mount the unit in an area that cannot be easily accessed by non-qualified personnel.
5. Do not install power supplies in places with high moisture or near water.
6. Do not install power supplies in places with high ambient temperature or near fire source.

7. Do not "daisy chain" power runs to monitors. All power runs from each display must go directly to the Power Supply.

Cable Guideline:

In most cases the CE-S320-B can safely power multiple LCDs and/or PVMs up to 240 Watts. For best results, use only high-quality 18 gauge cable or larger.

As a guide the reference charts to the right can help determine what cable to use.

When powering multiple LCDs or PVMs from a single Power Supply, it is recommended that cable lengths be grouped for similar run lengths to better maintain consistent voltage levels at the respective monitors.

For a 0.8A M8S, M8SD & M10S. S320-B adjusted to 27 Volts DC

| Gauge AWG | Voltage drop per 100 ft | Max. Cable length (7 volt drop) |
|-----------|-------------------------|---------------------------------|
| 18 | 1.08 Volts | 650 feet |
| 16 | .7 Volts | 1000 feet |

For a 2.1A M19S & M27S with S320-B adjusted to 27 Volts DC

| Gauge AWG | Voltage drop per 100 ft | Max. Cable length (7 volt drop) |
|-----------|-------------------------|---------------------------------|
| 18 | 2.7 Volts | 260 feet |
| 16 | 1.7 Volts | 410 feet |
| 14 | 1.05 Volts | 666 feet |

For a 2.5A M32S. CE-S320-B adjusted to 27 Volts DC

| Gauge AWG | Voltage drop per 100 ft | Max. Cable length (7 volt drop) |
|-----------|-------------------------|---------------------------------|
| 18 | 3.17 Volts | 224 feet |
| 16 | 2 Volts | 350 feet |
| 14 | 1.25 Volts | 560 feet |

1. MOUNTING

1a. Remove Cover Plate

Remove the four screws from the corners of the cover plate. Set the screws aside and save for Truss Mount and Wall Mount applications.

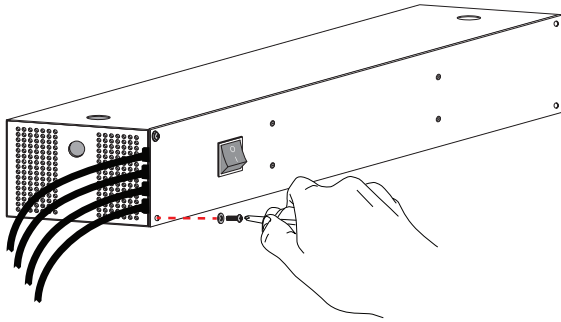

1b. Rack Mount

Pull the front cover assembly and wiring away from the chassis and proceed to the wiring instructions. The chassis will not be used for Rack Mount applications.

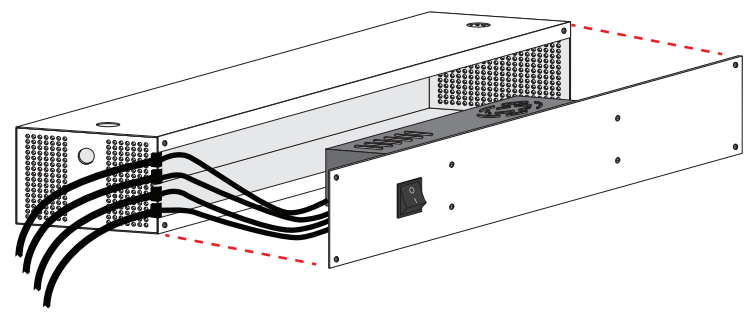

1c. Truss Mount

Insert *bolts through the holes on the top inside of the chassis. Place the chassis under the truss, positioning the ends of the bolts through the open slot in the truss. Place *washers over the bolts, then place and tighten nylon lock *nuts on the bolts. (bolts, washers and nuts not included)

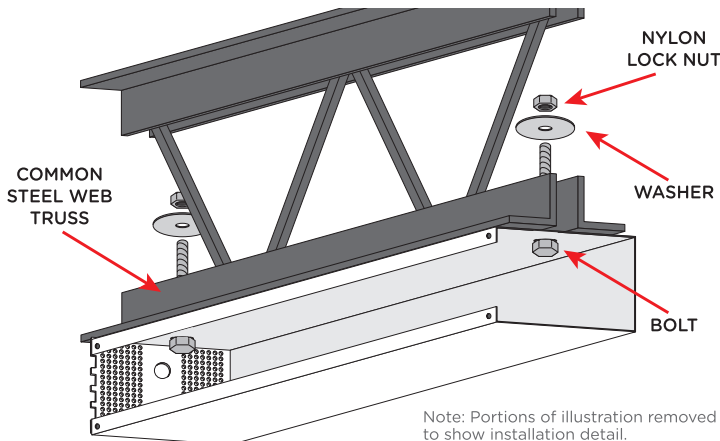

1d. Wall Mount

Remove the cover plate assembly as detailed in the Rack Mount instructions. Place the chassis against the wall. Fasten to the wall using sufficient length 1/4" *bolts or *screws, preferably into studs. (Mounting screws/bolts not included)

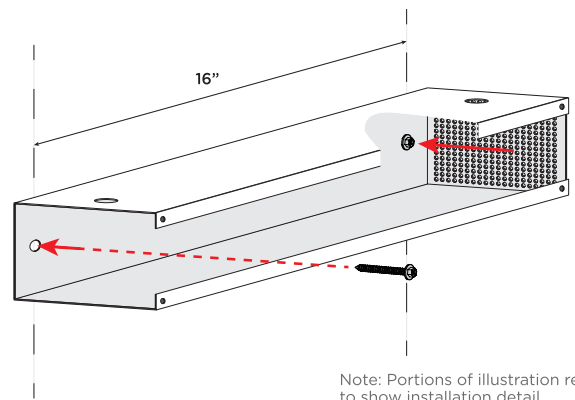

You may wish to mark the holes (located 16" on center) with a pencil, then remove chassis from wall and drill pilot holes.

2. REASSEMBLE

a. If being Truss or Wall Mounted, reattach the power supply cover plate assembly to the chassis with the 4 screws that were removed in step 1.

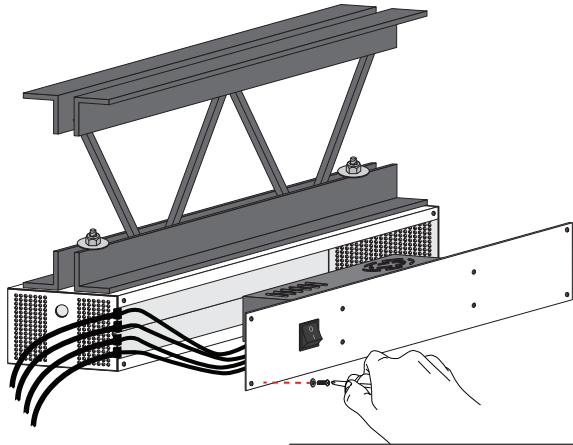

Truss Mount Option Shown



WARNING

FRONT COVER ASSEMBLY MUST BE SECURELY ATTACHED TO THE CHASSIS TO SATISFY UL LISTING.

Rack Mount Option Shown

b. If Rack Mounting, install the power supply cover plate assembly to the rack with rack-mount screws, (not included).

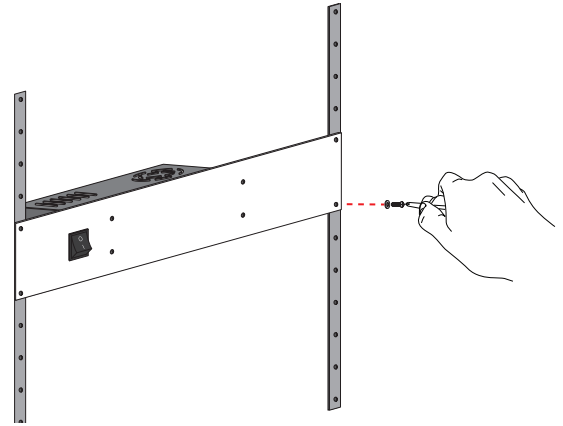

3. WIRING

a. The CE-S320-B is equipped with three wired leads with pre-installed crimp connectors. Simply insert the positive and negative wires from your monitors into the connectors, and crimp to connect. The power supply leads are indicated with red shrink tubing for positive and black shrink tubing for negative. Be sure to maintain proper polarity, otherwise displays may be damaged or not function correctly.

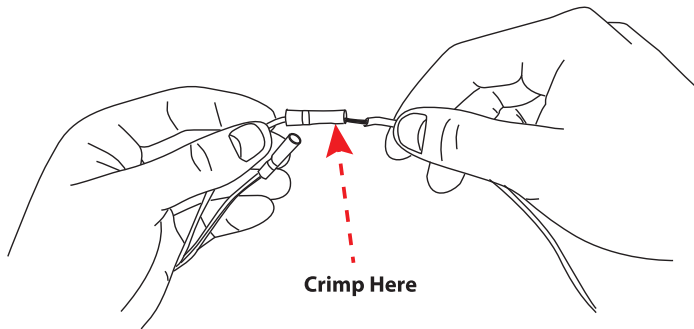

b. Plug in the AC plug into a nearby outlet and turn the main rocker switch 'ON'.

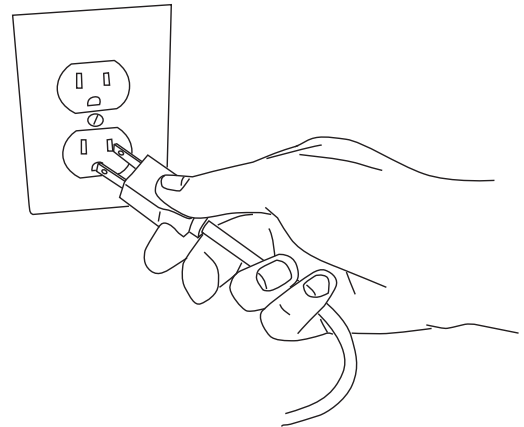

4. ADJUSTMENTS

There is a voltage adjustment pot adjacent to the terminal block that allows the voltage to be adjusted from 20-27 volts DC. The output is factory set at 24 volts, which is the recommended setting for minimum stress on the power supply and display. If you do not have enough voltage to the display, use a Phillips head screwdriver to gently turn the pot clockwise to increase voltage to the appropriate level.

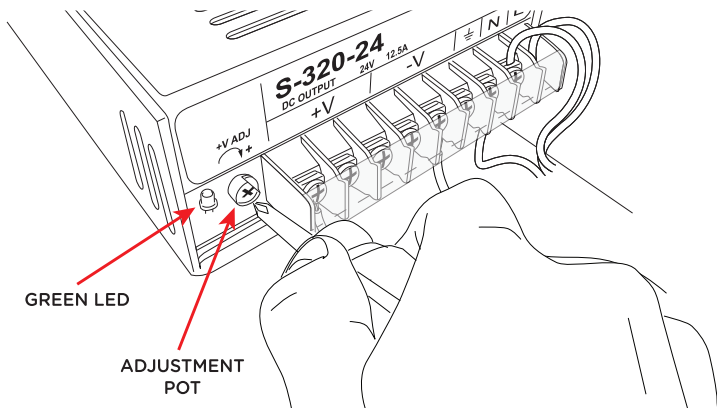

It is recommended to disconnect the power supply from power source prior to making adjustments to voltage.

5. TROUBLESHOOTING

No power at monitor:

- Ensure Power Supply is connected to live AC outlet and switch is on.
- Check the connections of the cables at the terminal block.
- Check the green LED on the Power Supply, located next to the terminal block. If LED is flashing there is a short in the wiring or it is cross wired.

Monitor has power, but doesn't function properly:

- Insufficient voltage at monitor. Often caused by long cable runs, "daisy chaining" cable runs, or too small of gauge of wire. Adjust +V ADJ pot on Power Supply clockwise until display functions properly. (see step 7. ADJUSTMENT) If this does not remedy the problem, rewiring may be required.

Monitor has no image:

- Check LED on front of monitor, if green the display is powered and receiving the correct signal.
- If LED is amber or flashing the display is receiving power, but not a proper video signal or the video input selector on the display is not set to the proper setting. Select proper input on display.
- If LED is not lit, check power switch on display. If still not lit, unit is not receiving proper power. Check polarity of DC power to ensure this is correct. The internal pin of the connector is positive and the outer barrel is negative. Checking voltage at connector must be done with a load. You will not get an accurate voltage measurement if not connected to the display when measuring, due to the voltage drop of the cabling.