

IDX Series [IR] Install Guide

For IR LED Equipped Cameras: IDX18(B) • IDX30(B) • IDX50(B)

Included Items:

- IDX Series Camera x 1
- Mounting Plate x 1
- 4x20mm Screws x 4
- Instructions x 1
- Test Monitor BNC Lead x 1
- Mounting Template x 1

Required Items:

- Phillips Head Screwdriver or Drill with Phillips Head Bit

Optional Items:

- CE-REMOTE (OSD Remote Control)

1. INSTALL MOUNTING PLATE

Secure the Mounting Plate to a compatible conduit box (Single Gang, Double Gang, 3-1/4" & 3-1/2", or 4" Oct/Rd) using the screws that came with the conduit box, or mount to a solid surface using the 4 screws included with this camera.

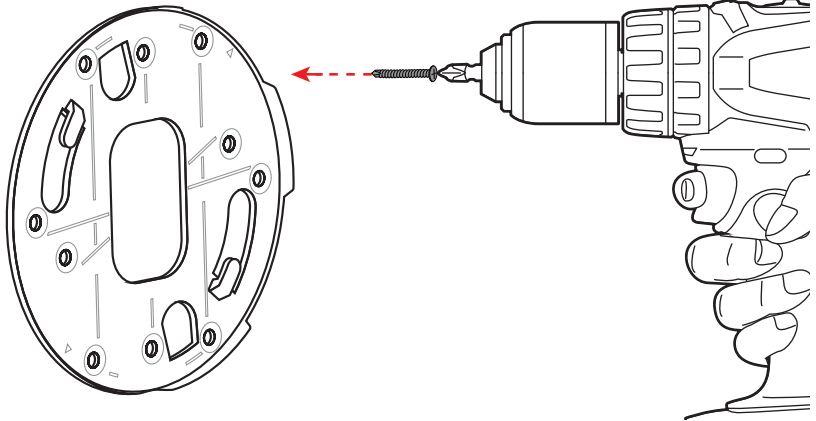

NOTE: It is recommended to use drywall anchors if mounting to drywall. Drywall anchors not included.

2. REMOVE DOME COVER

Hold the dome cover with one hand while gripping the finger grip tabs on the bottom of the camera base. Turn the finger grip tabs (camera base) counter-clockwise to separate it from the dome cover.

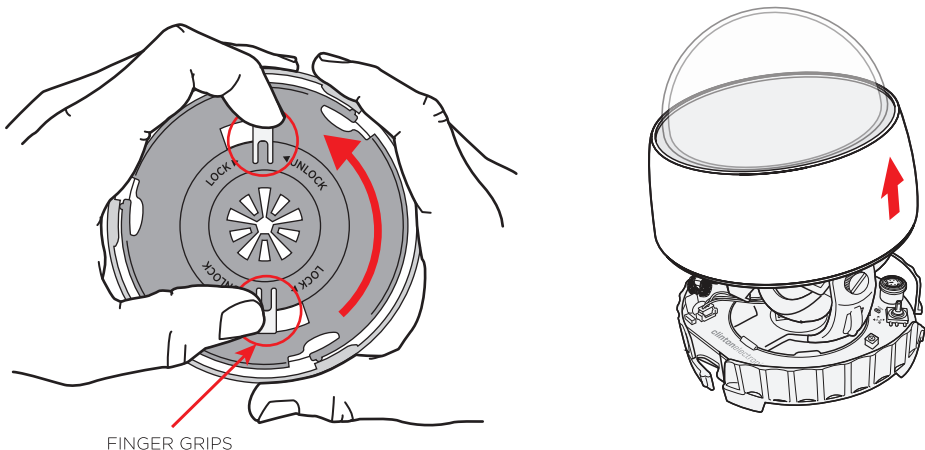

3. CONNECT CABLES

Make connections to the BNC cable and the power connection. Feed any cable slack into the mounting surface. A Power LED (on the circuit board) will illuminate GREEN when the camera is receiving correct power. To ensure quality operation, verify proper BNC and power termination, along with proper voltage at camera.

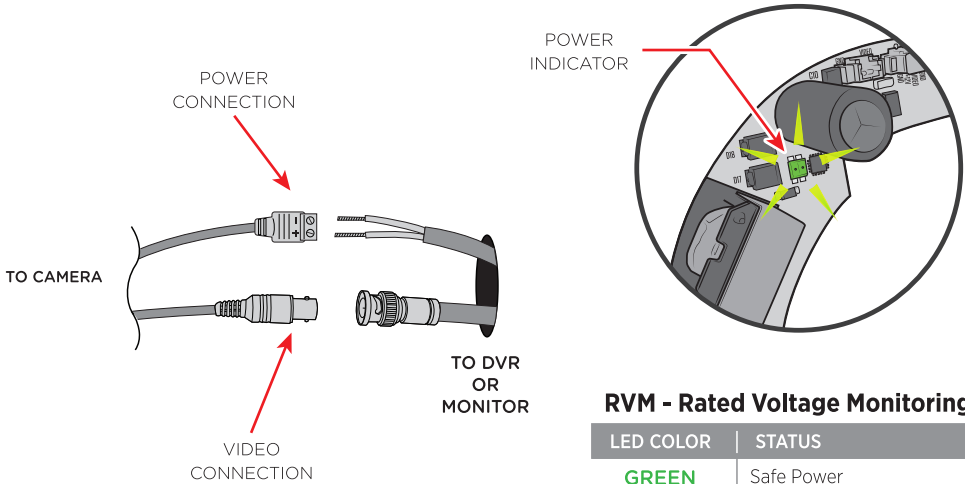

RVM - Rated Voltage Monitoring

LED COLOR	STATUS
GREEN	Safe Power
RED - SOLID	Over 29 Volts (AC24V)
RED - BLINK	Under 10 Volts (DC12V)

4. ATTACH CAMERA TO MOUNTING PLATE

Attach the camera to the mounting plate by aligning the hooks on the mounting plate to the tabs on the camera base. Twist the camera base clockwise to lock it in place.

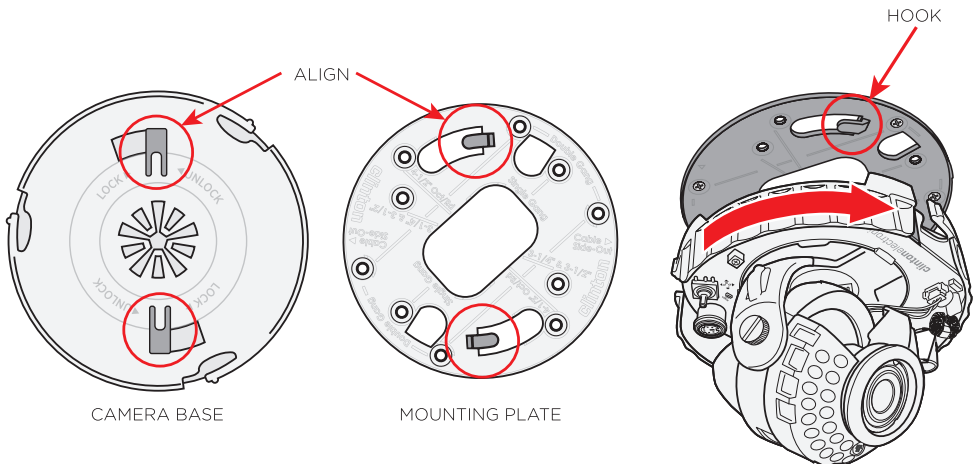

5. TEST MONITOR / OSD CONTROL

To test the camera with a test monitor use either the supplied Test Monitor BNC Lead or optional CE-REMOTE. The Test Monitor BNC Lead plugs into the small, 2 PIN connector (marked CN2) next to the wide 12 wire connection on the circuit board. The CE-REMOTE plugs into the DIN Port. OSD Adjustment can be made by using the OSD Joystick or the optional CE-REMOTE. Refer to OSD Manual for detailed instructions on adjusting camera settings.

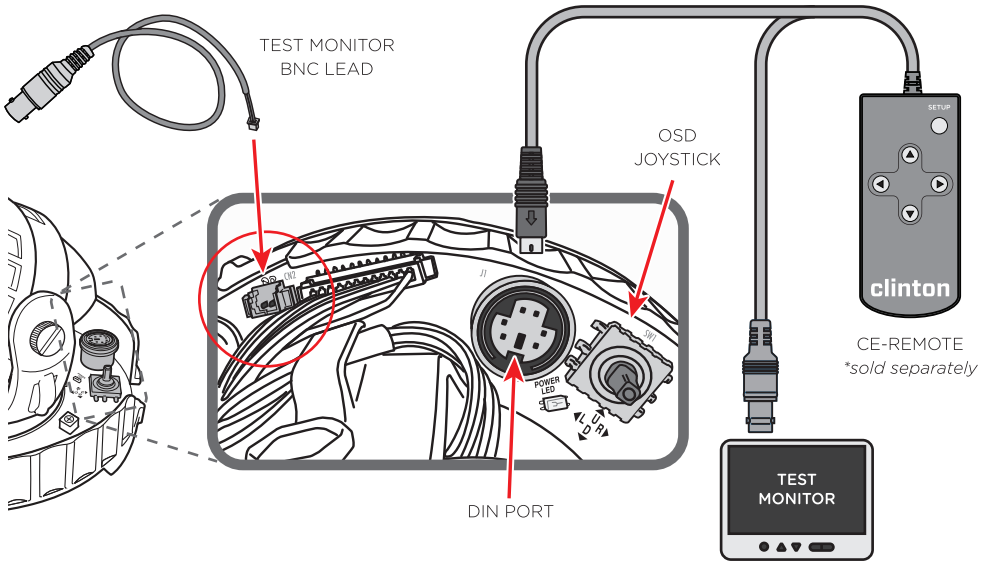

6. CAMERA ANGLE ADJUSTMENT

Adjust the angle of the camera as necessary. It is recommended to test the operation and intensity of the IR LEDs. To test, cover the IR Sensor and verify that the IR LEDs turned 'ON'. To adjust the intensity of the IR LEDs, use a Phillips head screwdriver to turn the IR level adjustment potentiometer, (located next to the OSD Joystick on the board). Turn the screw to the RIGHT (clockwise) for brighter LEDs or to the LEFT (counter-clockwise) for dimmer LEDs.

A. Lens Rotation: Rotate the U-Bracket on the gimbal to adjust.

B. Lens Angle: Loosen thumb screws on each side to adjust the tilt of the lens.

C. Camera Plate Rotation: Pinch the gimbal U-Bracket and rotate the camera assembly on the base.

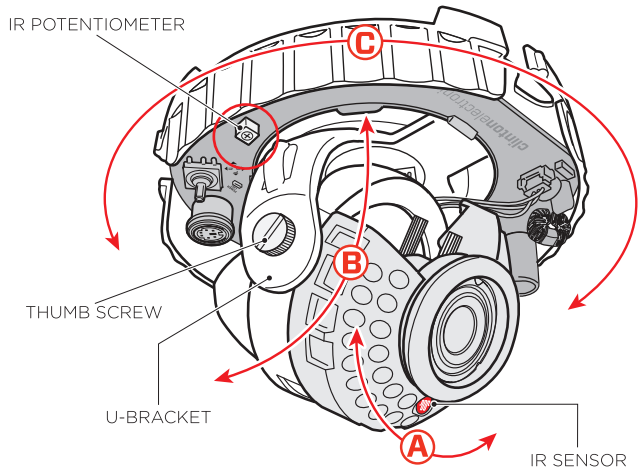

7. ZOOM/FOCUS ADJUSTMENT

Loosen the appropriate adjustment lever by turning counter-clockwise. To widen the viewing angle, rotate the Zoom lever to the Left. To narrow the viewing angle rotate the ZOOM lever to the Right. Rotate the Focus lever Left or Right to focus the lens.

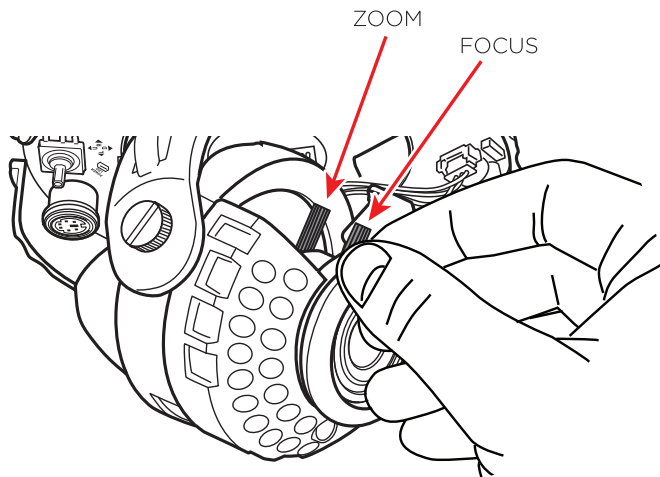

After zoom / focus adjustments have been made, tighten the adjustment levers to lock the adjustments.

8. REPLACE DOME COVER

Carefully replace the dome cover onto the camera assembly by twisting the dome cover clockwise to lock into place. Make sure the IR Sensor is free from obstruction and will not be covered by the dome cover once it is re-attached. If the sensor is covered it will cause the IR LEDs to be on all the time.

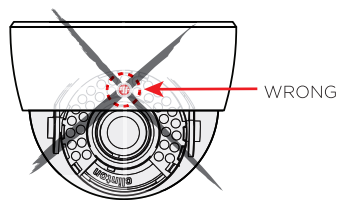
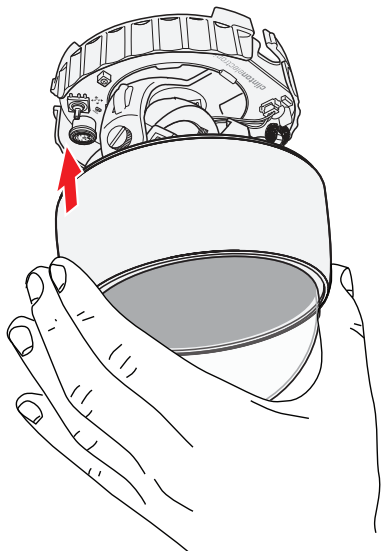

IR SENSOR LOCATION

