

CE-1290W-1

Clamp-On 3-Axis Pole Mount



Maximum Load Capacity: 22 lbs / 10 kgs



KEY FEATURES:

- Clamps on 1 $\frac{3}{16}$ " - 2 $\frac{1}{8}$ " round pole or $\frac{7}{8}$ " - 1 $\frac{1}{2}$ " square tubing
- Vertical or Horizontal Mounting
- Mounts monitor approx 5 $\frac{1}{2}$ " from pole
- 3-Axis Adjustable
- VESA 75
- Includes Mounting Hardware
- UL Listed

** Recommended for LCD or PVM up to: 22 lbs*



GENERAL

Materials	Steel
Dimensions L x W x H	8" x 4.72" x 3.5" 203mm x 120mm x 89mm
Weight	2.55 lbs / 1.15 kg

DIMENSIONS:

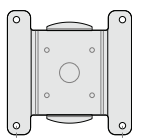
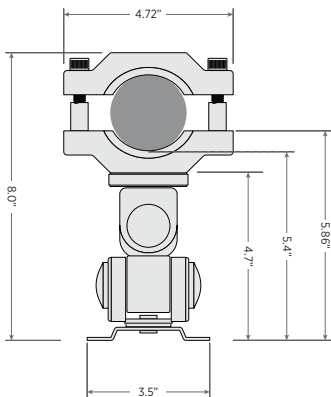

Unit: INCHES

VESA 75

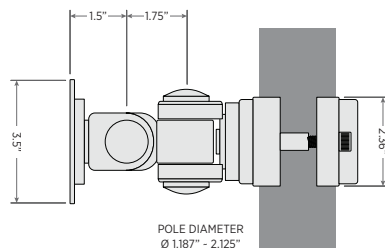

POLE DIAMETER
Ø 1.187" - 2.125"