

# CE-IDX1HDA Install Guide

For Analog / HD Analog IDX Dome Cameras

## Included Items:

- IDX Series Camera x 1
- Mounting Plate x 1
- 4x20mm Screws x 4
- Instructions x 1

- Test Monitor BNC Lead x 1
- Mounting Template x 1

## Required Items:

- Phillips Head Screwdriver or Drill with Phillips Head Bit
- DC12V or AC24V Power Supply

## Optional Items:

- CE-REMOTE (OSD Remote Control)

## 1. INSTALL MOUNTING PLATE

Secure the Mounting Plate to a compatible conduit box (Single Gang, Double Gang, 3-1/4" & 3-1/2", or 4" Oct/Rd) using the screws that came with the conduit box, or mount to a solid surface using the 4 screws included with this camera.

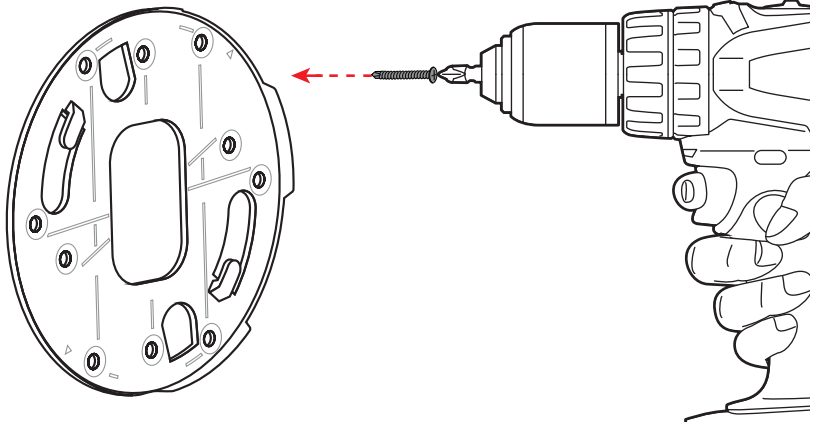

**NOTE:** It is recommended to use drywall anchors if mounting to drywall. Drywall anchors not included.

## 2. REMOVE DOME COVER

Hold the dome cover with one hand while gripping the finger grip tabs on the bottom of the camera base. Turn the finger grip tabs (camera base) counter-clockwise to separate it from the dome cover.

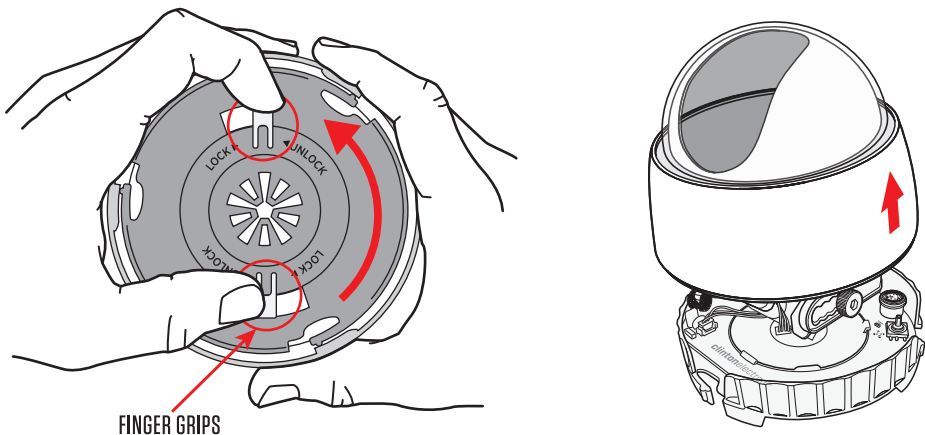

### 3. CONNECT CABLES

Make connections to the BNC cable and the power connection. Feed any cable slack into the mounting surface. A Power LED Indicator (on the circuit board) will illuminate GREEN when the camera is receiving correct power. To ensure quality operation, verify proper BNC and power termination, along with proper voltage at camera.

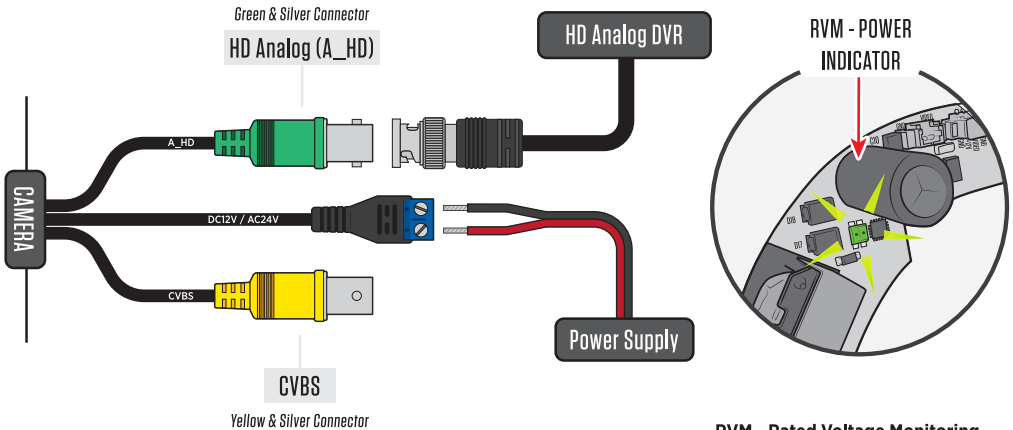

**Default HD Analog Output: A\_HD**

HD Analog output selectable: (A\_HD / C\_VI / T\_VI)  
Use OSD Menu to change HD Analog signal output

#### RVM - Rated Voltage Monitoring

LED COLOR	STATUS
GREEN	Safe Power
RED - SOLID	Over 29 Volts (AC24V)
RED - BLINK	Under 10 Volts (DC12V)

### 4a. ATTACH CAMERA TO MOUNTING PLATE (for cable exiting through mounting plate)

Attach the camera to the mounting plate by aligning the hooks on the mounting plate to the tabs on the camera base. Twist the camera base clockwise to lock it in place.

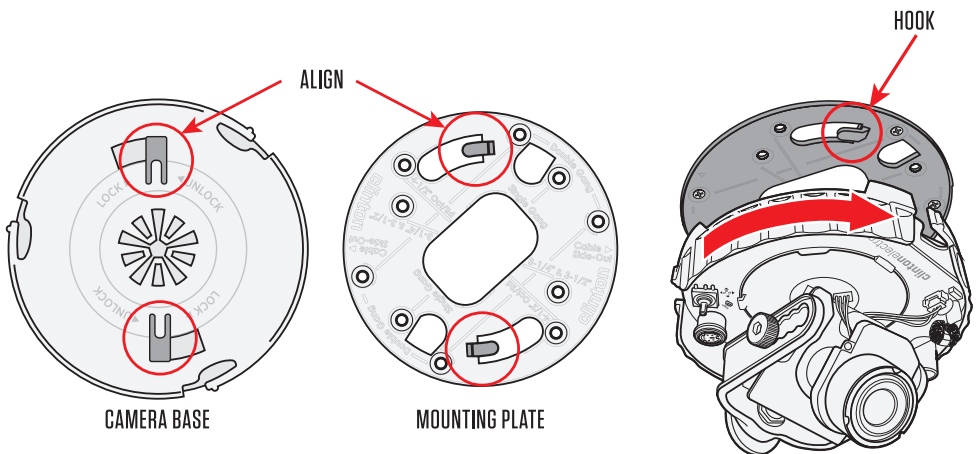

#### 4b. ATTACH CAMERA TO MOUNTING PLATE (for cable side exit)

When running the cable out the side of the camera rather than through the center hole in the mounting plate, hold the cable to the camera base where it says "CABLE SIDE OUT." Align the cable exiting the camera to the notched out area on the mounting plate marked "Cable Side-Out"

Attach the camera to the mounting plate by aligning the hooks on the mounting plate to the tabs on the camera base. Twist the camera base clockwise to lock it in place.

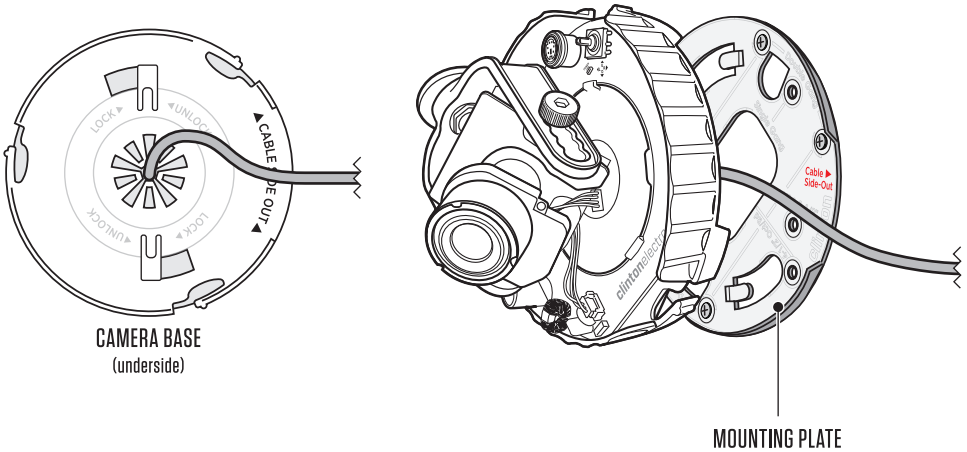

To allow the cable to exit the side of the dome cover, remove the tab marked with an arrow (on the inside of the dome cover) with a pair of needle-nose pliers.

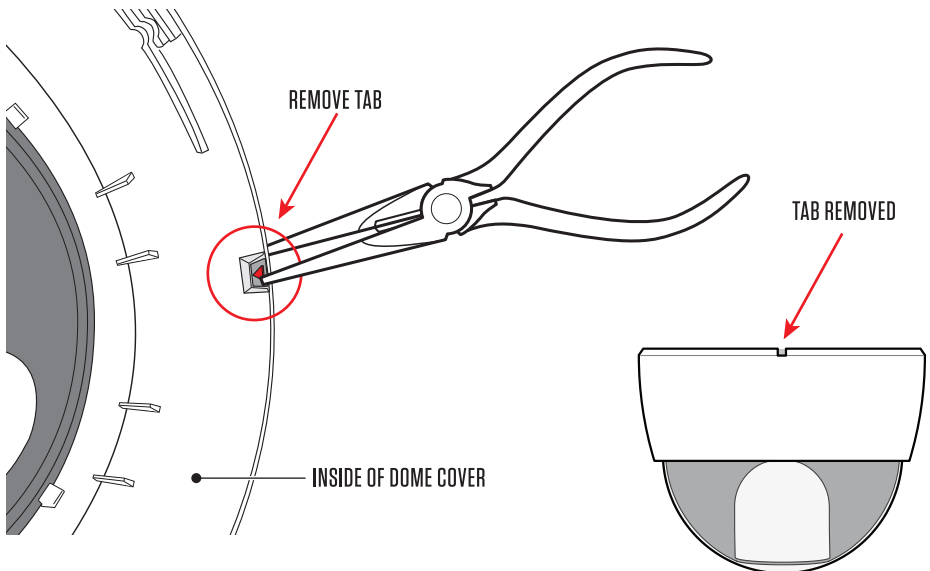

## 5. TEST MONITOR / OSD CONTROL

To test the camera with a test monitor use either the supplied Test Monitor BNC Lead or optional CE-REMOTE. The Test Monitor BNC Lead plugs into the small, 2 PIN connector (marked CN2) next to the wide 12 wire connection on the circuit board. The CE-REMOTE plugs into the DIN Port. OSD Adjustment can be made by using the OSD Joystick or the optional CE-REMOTE. Refer to OSD Manual for detailed instructions on adjusting camera settings.

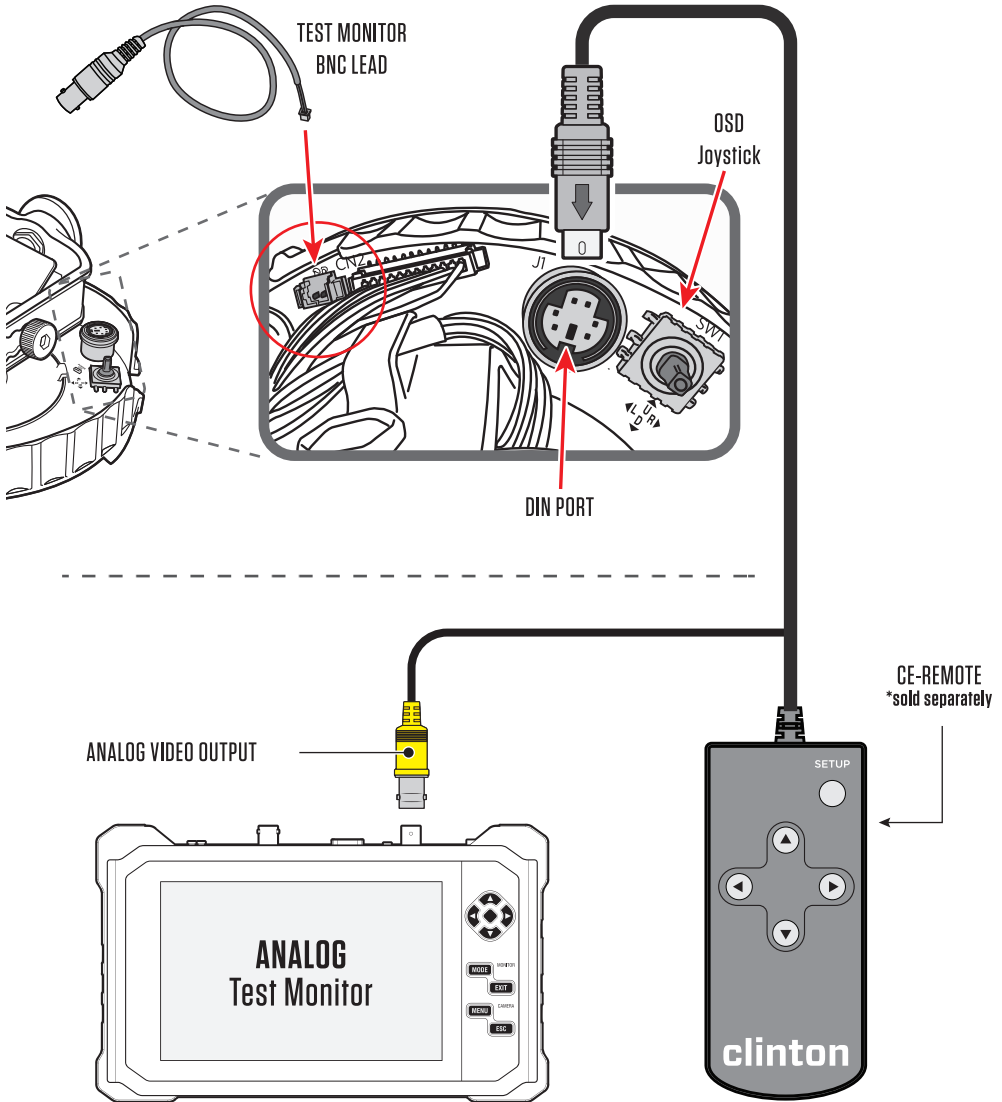

**NOTICE**

The test monitor connection on the CE-REMOTE and the 2-pin connector on the camera board are CVBS/analog video outputs. The output will be the same from these connections as the Yellow BNC connector. Certain OSD menu options such as WDR only function with HD Analog, and will disable CVBS if turned On.

## 6. CAMERA ANGLE ADJUSTMENT

Adjust the angle of the camera as necessary.

**A. Lens Rotation:** Rotate the U-Bracket on the gimbal to adjust.

**B. Lens Angle:** Loosen thumb screws on each side to adjust the tilt of the lens.

**C. Camera Plate Rotation:** Pinch the gimbal U-Bracket and rotate the camera assembly on the base.

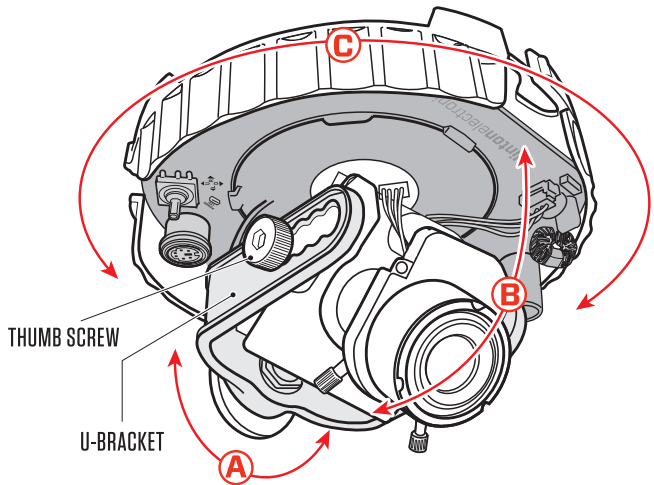

## 7. ZOOM/FOCUS ADJUSTMENT

Loosen the appropriate adjustment lever by turning counter-clockwise. To widen the viewing angle, rotate the Zoom lever to the Left. To narrow the viewing angle rotate the ZOOM lever to the Right. Rotate the Focus lever Left or Right to focus the lens.

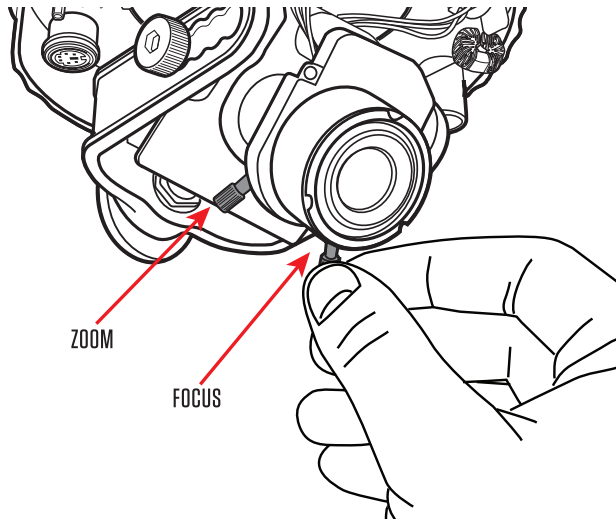

*After zoom / focus adjustments have been made, tighten the adjustment levers to lock the adjustments.*

## 8. REPLACE DOME COVER

Prior to replacing the dome cover (for cameras without IR LEDs) remove the protective film on the inside of the dome cover. Carefully replace the dome cover onto the camera assembly by twisting the dome cover clockwise to lock into place. It may be necessary to rotate the clear dome slightly to align the cut out in the mask with the lens.

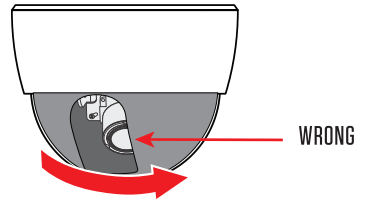
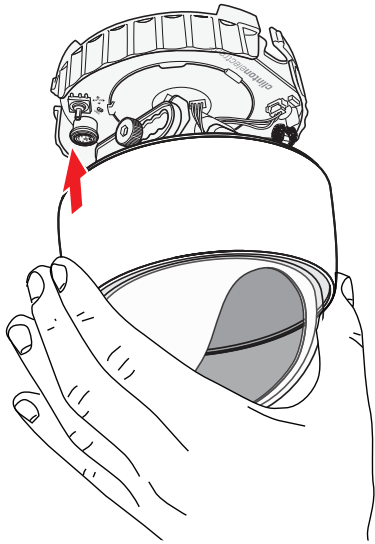

ROTATE DOME AS NECESSARY

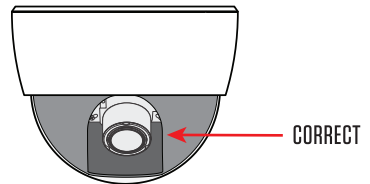

## 9. PERIODIC DOME CLEANING

Over time, dome cameras often collect dirt and dust on the outside of the polycarbonate dome bubble. This can cause blurry images. We recommend periodically cleaning the dome to ensure optimal day and night image quality.

To clean the outside of the dome: first use compressed air to blow off any significant amounts of dirt/dust – then use warm, soapy water and a damp micro-fiber cloth towel to clean. Dry with a separate, clean micro-fiber cloth towel.

*Glass cleaner, Ammonia, alcohol and/or other solvents should never be used to clean the dome. These products contain harsh chemicals that can cause corrosion and reduce optical clarity. Paper towels, shop-rags, or other rough fabric should also never be used to dry the dome as they can scratch the dome.*

✔ SAFE TO USE



Warm Soapy Water

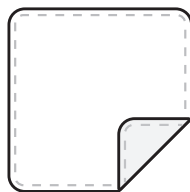

Micro-Fiber Cloth

✘ DO NOT USE



Glass Cleaner

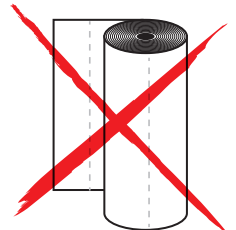

Paper Towels

## 10. HD ANALOG IMAGE TIPS

Because the HD Analog signal loses chroma (color) and luminance (brightness) over distance, sometimes the image at the DVR might appear desaturated and lacking brightness when compared to how the image looks using a test monitor at the camera.

Before making image adjustments at the camera, try adjusting the color saturation and brightness at the DVR (if the DVR has camera image adjustments).

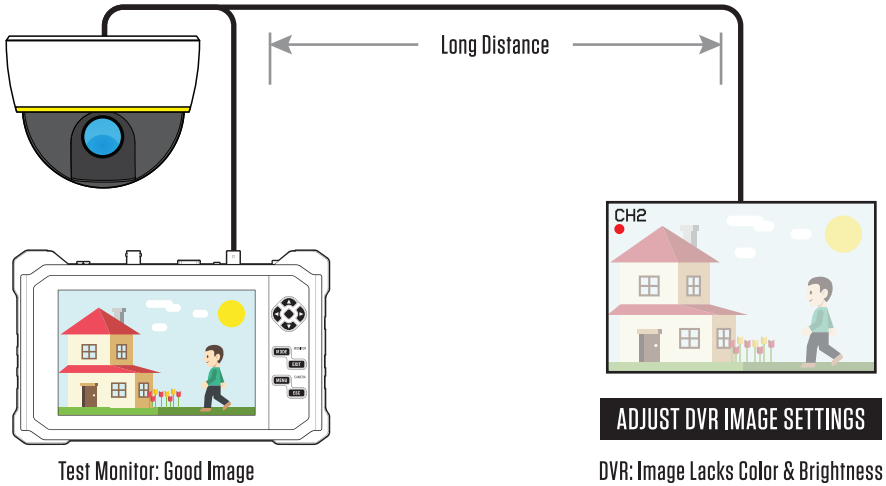

## 11. DUAL VIDEO OUTPUTS

The CVBS and HD Analog outputs from the camera can be used simultaneously. The GREEN connection should connect to the DVR. The YELLOW connection should typically go to a remote spot monitor or other CVBS/Analog device.

Connecting the GREEN, HD Analog output to the majority of monitors will result in no image or a scrambled image. The HD Analog signal is not compatible with standard analog equipment.

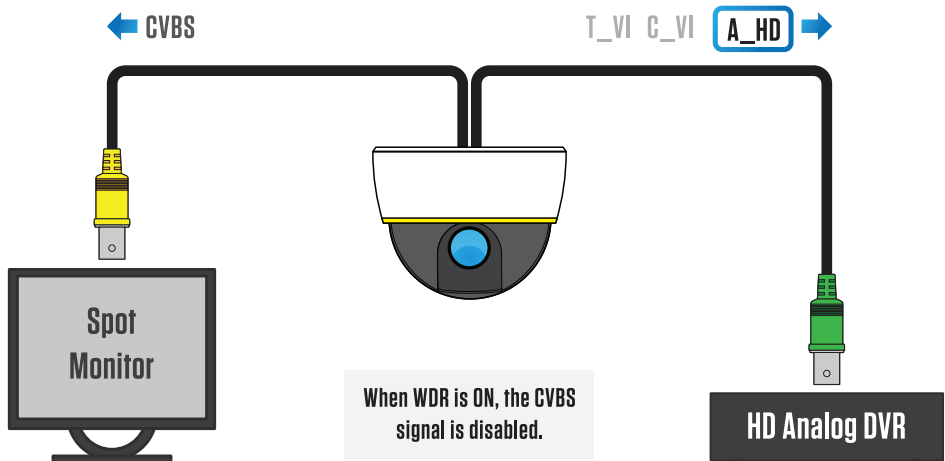

# HD ANALOG

*\*This camera's default HD Analog video output is set to: A\_HD*

## HD Analog Compatibility

While Analog (CVBS) and HD Analog (T\_VI, C\_VI, A\_HD) share the same type of BNC connectors, they're different signal types that are not compatible with each other.

Use the **GREEN BNC connector for HD Analog** Output (Yellow connector is CVBS).



## HD Analog will not work on Analog only DVRs, Monitors & Devices

Because there are signal tuning variations between each HD Analog DVR manufacturer— we can not guarantee that the HD Analog output from the camera will display correctly with off-brand equipment.

## HD Analog Distance

HD Analog signals degrade with long runs of cable. The image can appear washed out and lacking color saturation (black & white). Cable splices, improper BNC termination, damaged shielding, kinks and severe bends in the cable will reduce the possible video transmission distance and quality.

## HD Analog Output

Before changing the HD Analog output of the camera, check the compatibility of the DVR to ensure that it can accept the desired camera output. Selecting an incorrect HD Analog output from the camera can result in poor video quality or no video on the DVR.

To change the HD Analog Output: Enter the OSD Menu of the camera, then access the SYSTEM Menu. Select the desired HD Analog Output (**A\_HD**, **T\_VI**, or **C\_VI**).

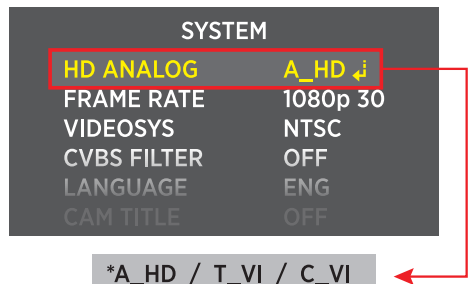

If you need further help call Clinton Electronics Technical Support at 800-549-6393.

*\*Information in this document is subject to change without notice*

v.03.02.21