

Telescoping Monitor Pole Install Guide

Included Items:

- Telescoping Pole
- Receiver Bracket
- Mounting Hardware
- Rivet(s)
- Safety Cable
- VESA Plate(s)

Required Items:

- Phillips Head Screwdriver
- Drill with 3/16" Drill Bit
- 3/4" Wrench
- 5/16" Wrench
- 7/16" Wrench
- Hammer



ATTENTION!

USE ONLY AS DESIGNED

THIS MOUNT IS DESIGNED TO MOUNT A MONITOR OR PVM FROM THE CEILING STEEL SUPPORT TRUSS OR CHANNEL STRUT STRUCTURE. IT IS NOT DESIGNED TO MOUNT TO A WOODEN SURFACE. IT IS INTENDED FOR USE ONLY WITH THE MAXIMUM WEIGHT INDICATED. USE WITH PRODUCTS HEAVIER THAN THE MAXIMUM WEIGHTS INDICATED MAY RESULT IN INSTABILITY CAUSING POSSIBLE INJURY.

1. Secure to Building Structure

1.1 Insert threaded rod between truss gap or into hole in channel strut.

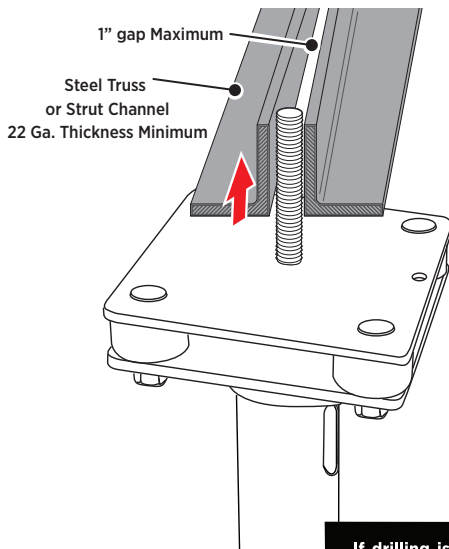

1.2 Place 1/2" fender washer over the threaded rod and then 1/2" lock nut.

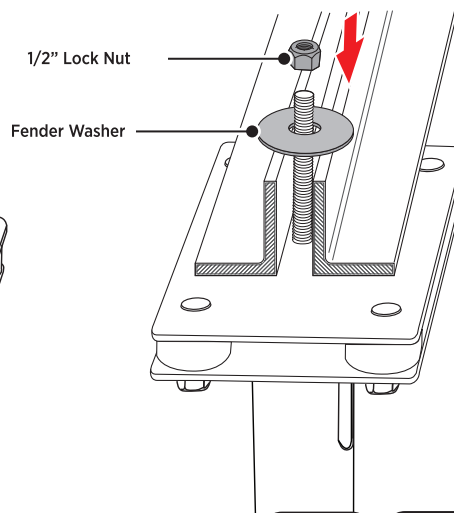

1.3 Tighten the 1/2"-13 lock nut using a 3/4" wrench.

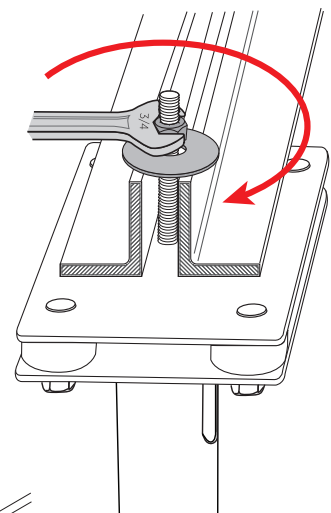

If drilling is necessary, use 9/16" metal drill bit to drill through steel mounting surface.

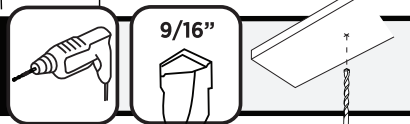

2. Adjust Height

While supporting the pole by the bottom end, loosen the twist-lock collar by turning it counter-clockwise. Extend the pole by gently lowering it to the desired height.

Once the height of the pole has been adjusted, lock the pole in position by rotating the twist-lock collar clockwise. The collar should be hand tightened as snug as possible to prevent the pole from extending (dropping down).

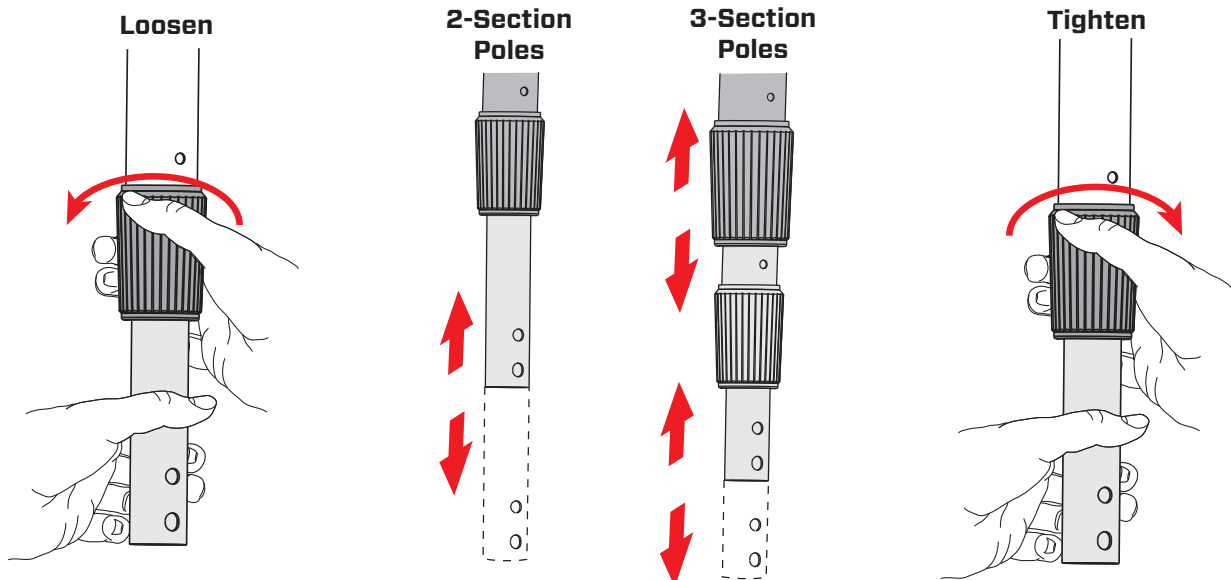

3. Install Rivet

After the pole is set to its desired length, drill a 3/16" hole through one side of the inner pole at the pre-drilled hole location in the outer pole. Insert the rivet until the backside of the head is flush with the outer surface of the pole. While supporting the backside of the pole, strike the pin sharply with a hammer to expand the rivet.

***Three-Section poles only:** Poles with three tube sections require two rivets to be installed, one for each section of telescoping pole length, (one above each locking collar). Repeat the steps above for each section of pole.

Drill hole

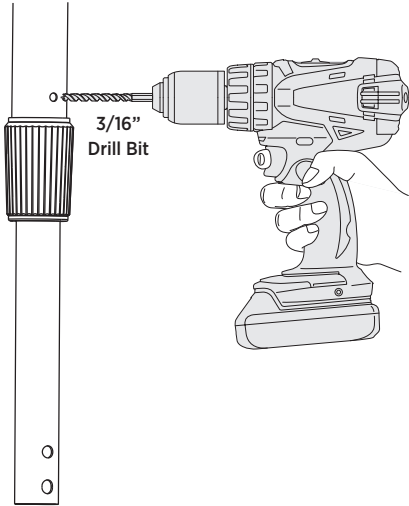

Insert Rivet

2-Section Poles
1 Rivet Required

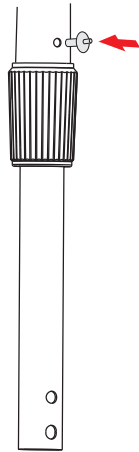

***3-Section Poles**
2 Rivets Required

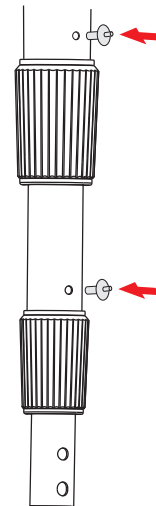

Expand Rivet

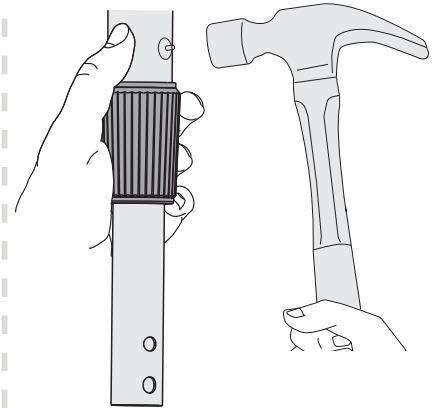

THE DRIVE RIVET IS REQUIRED TO MEET UL SAFETY REQUIREMENTS AND MUST BE INSTALLED.

4. Route Safety Cable

Loop the safety cable around the truss or nearby secure member of the building structure, and tighten nuts on the included wire clamp with a 5/16" wrench. Feed the eyelet end of the cable into the slotted hole near the top of the pole and down through the bottom of the pole.

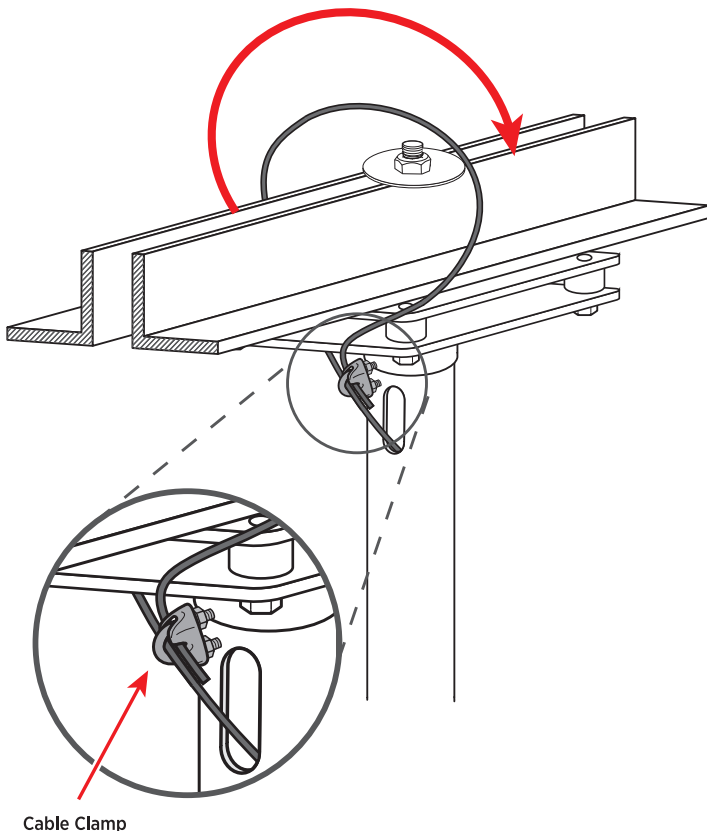

5. Route Cables

Feed the eyelet end of the safety cable, and desired power and video cables through the slotted hole near the top of the pole and down through the bottom of the pole.

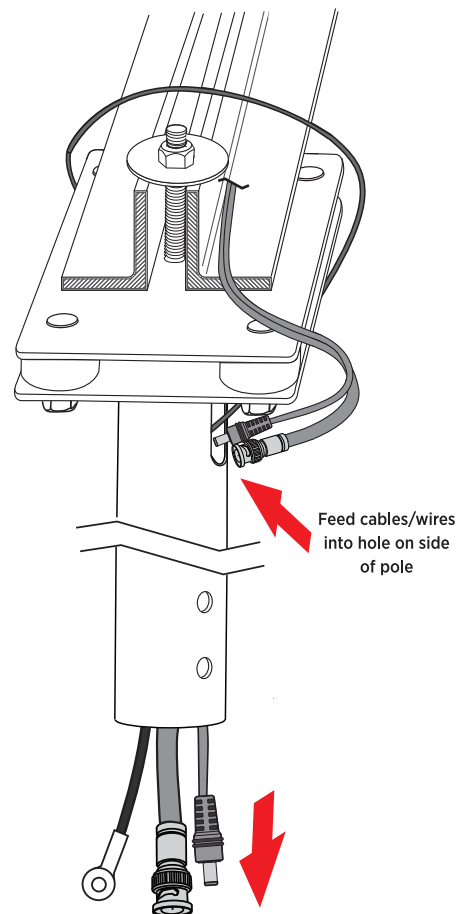

6. Attach VESA Plate

Place the VESA plate on the backside of the monitor. The "UP" indicator should be oriented towards the top of the monitor. Tighten the four M4 Phillips head screws into the 75mm or 100mm hole pattern.

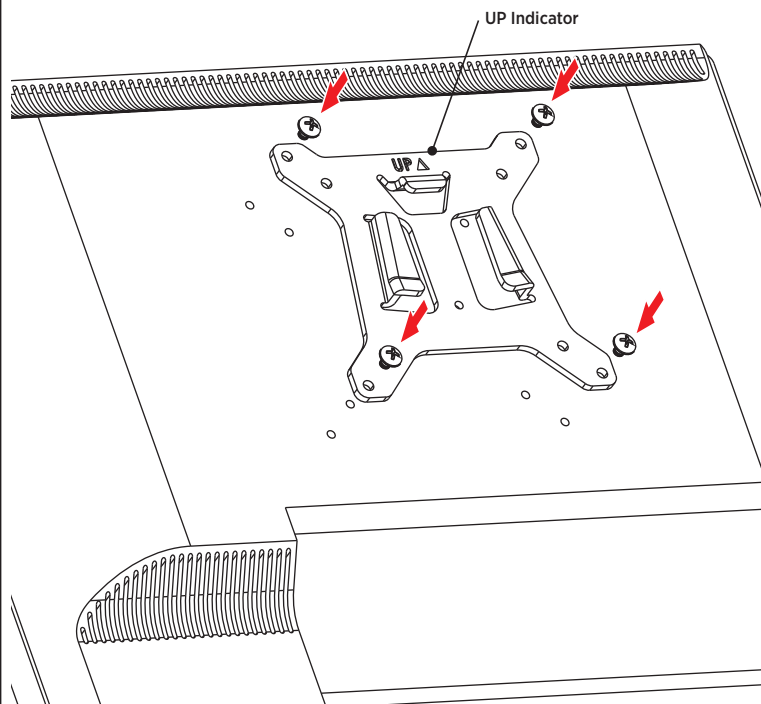

7. Attach Receiver Bracket

Slide the Receiver Bracket over the bottom end of the pole, and align the slot and square hole in the bracket to the holes on each side of the pole.

The square cutout should be positioned on the bottom end of the pole.

Slide the two carriage bolts into the side and through the bracket & pole. Place a washer on the opposite side of each bolt and using a 7/16" Wrench, securely fasten a lock-nut onto each bolt.

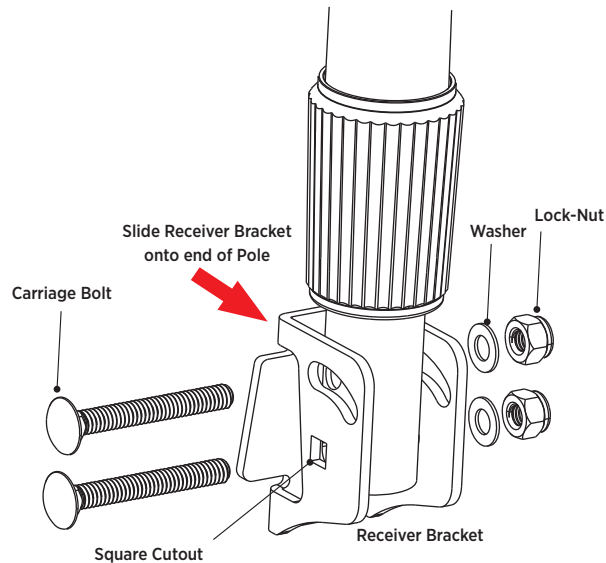

8. Hang Monitor

With the VESA plate secured to the monitor, slide the receiving hooks on the VESA plate over the tabs on the receiver bracket at the end of the pole.

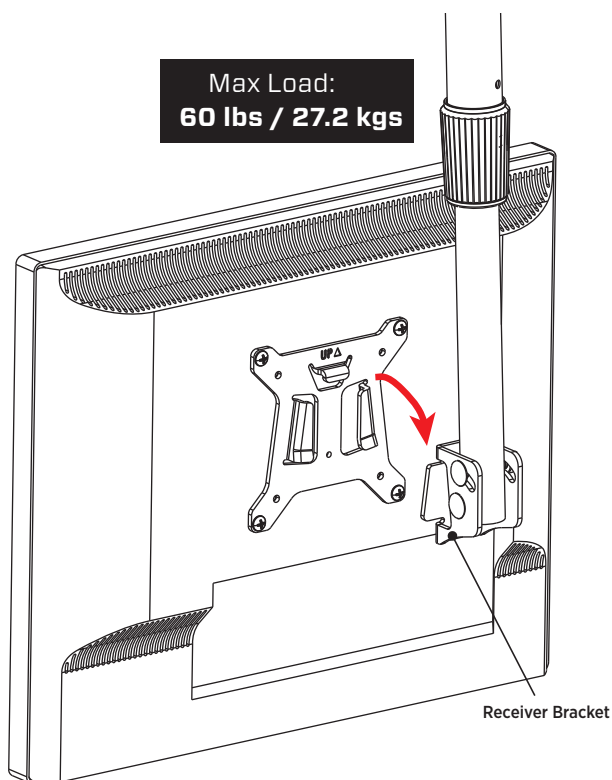

9. Attach VESA Retaining Screw

Screw the remaining 6mm long M4 screw through the backside of the receiver bracket, and into the threaded center hole in the VESA plate.

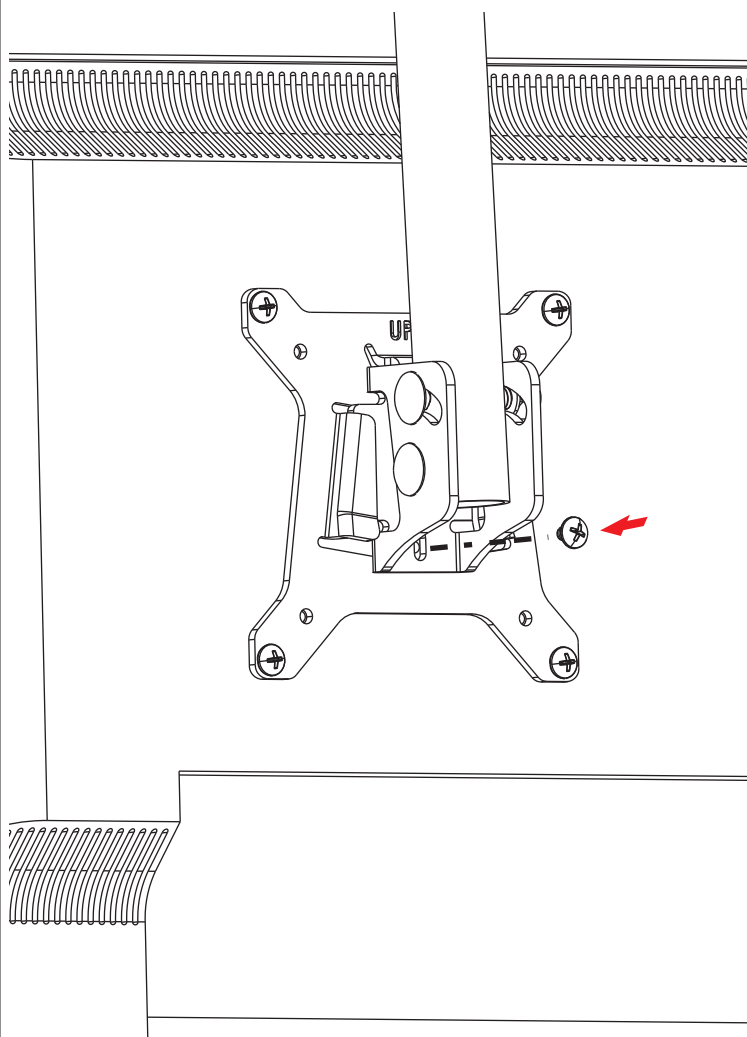

This mount is intended for use only with the maximum weights indicated. Use with products heavier than the maximum weights indicated may result in instability causing possible injury. This product is intended to mount to a steel support truss, or channel strut.

10. Attach Safety Cable

Attach the eyelet end of the safety cable to the monitor by securing the 10mm long M4 screw through the safety cable's eyelet, and into an available M4 hole in the monitor. If no other M4 holes are available in the monitor, remove one of the screws from the VESA plate, and replace it with the safety cable's screw.

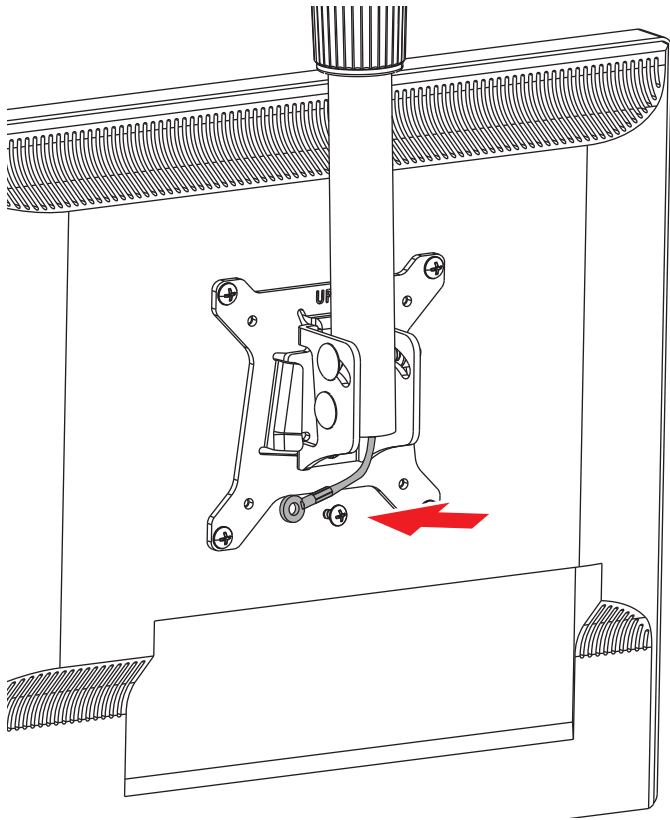

11. Adjust Angle

To adjust the angle of the monitor, loosen the upper locknut on the side of the Receiver Bracket with a 7/16" Wrench. Once the desired angle is set, ensure both upper and lower lock-nuts are firmly tightened.

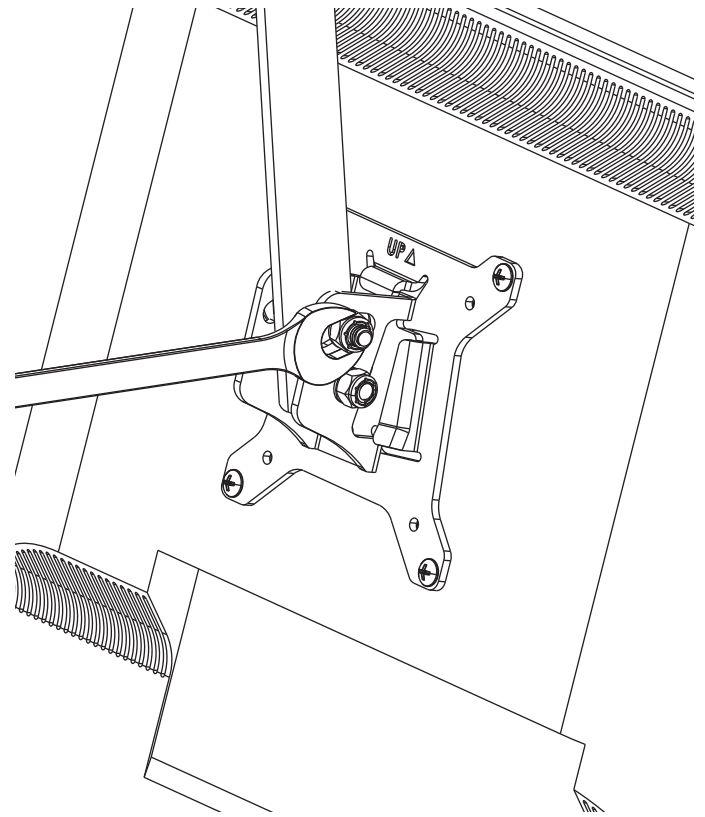

12. Level the Pole

12.1 You can ensure the pole is plumb by tightening the 1/4"-20 lock nuts on the top of the pole where it attaches to the structure using a 7/16" wrench.

12.2 Place a level on the pole and tighten the nuts that correspond to the direction that the pole needs to move (see illustration on the lower-right).

12.3 Check and adjust 2 adjacent sides of the pole until it is plumb in each direction.

